

1905 CLOSED VESTIBULE COACH

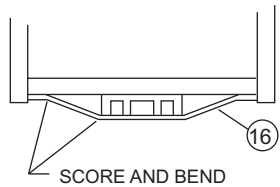

SCORE AND BEND

BEAM BRACE DETAIL

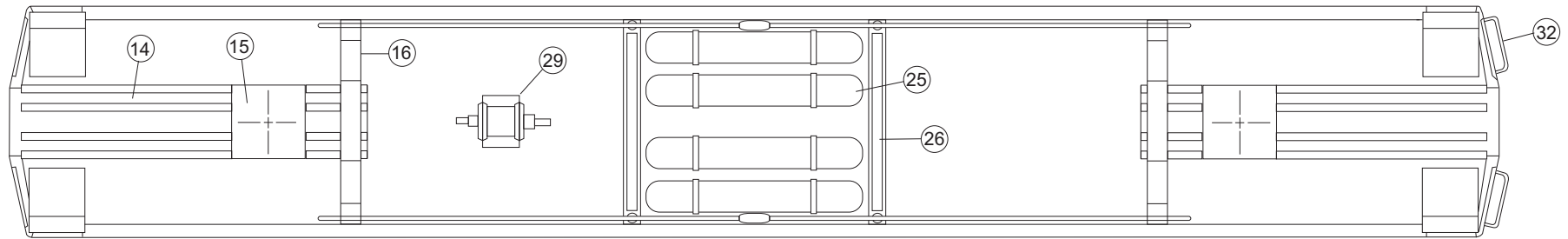
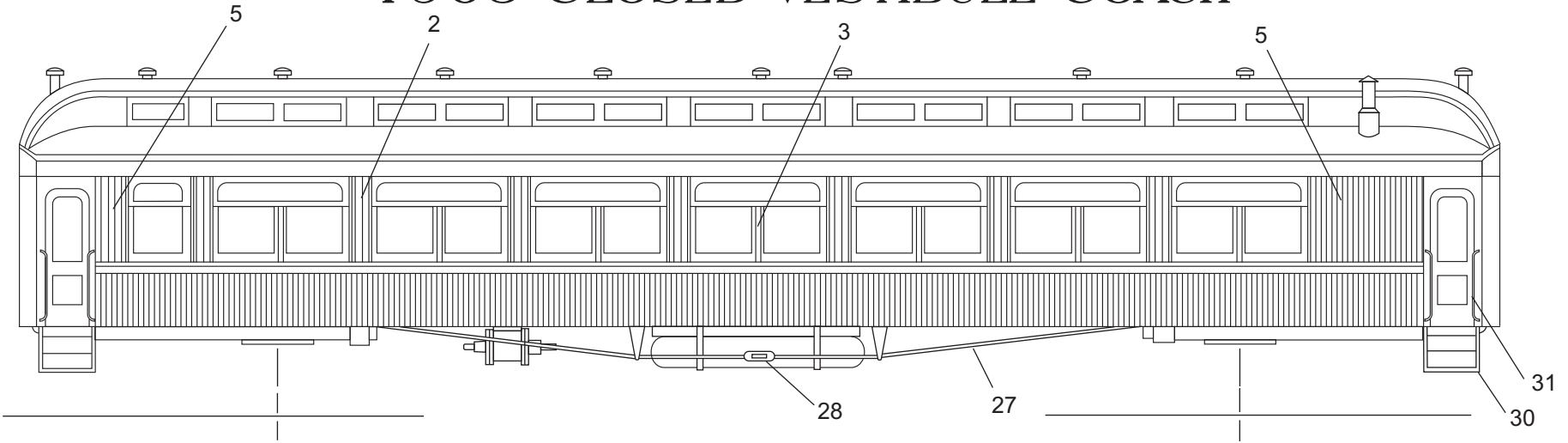
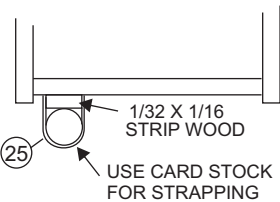

TANK DETAIL

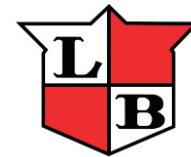
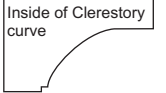
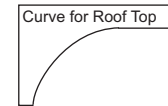
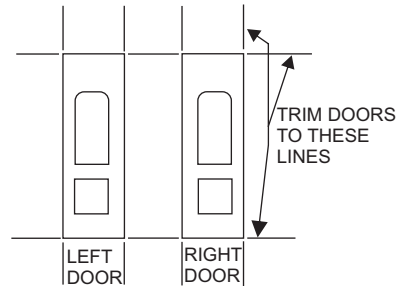
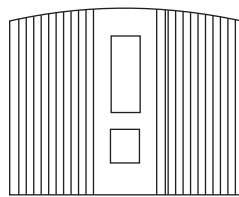
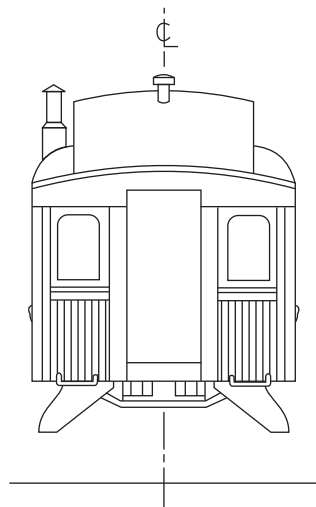

LaBelle Woodworking Company
 5101 Ridge Road
 Cheyenne, Wyoming 82009
 Phone : 307-433-9909 Fax: 307-433-9949
 Toll Free: 866-246-9967 (Voice Only)
 e-mail: info@labellemodels.com

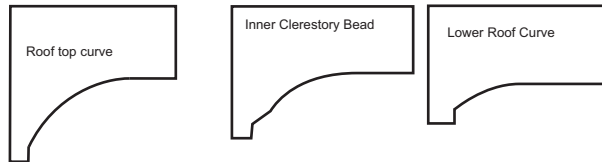
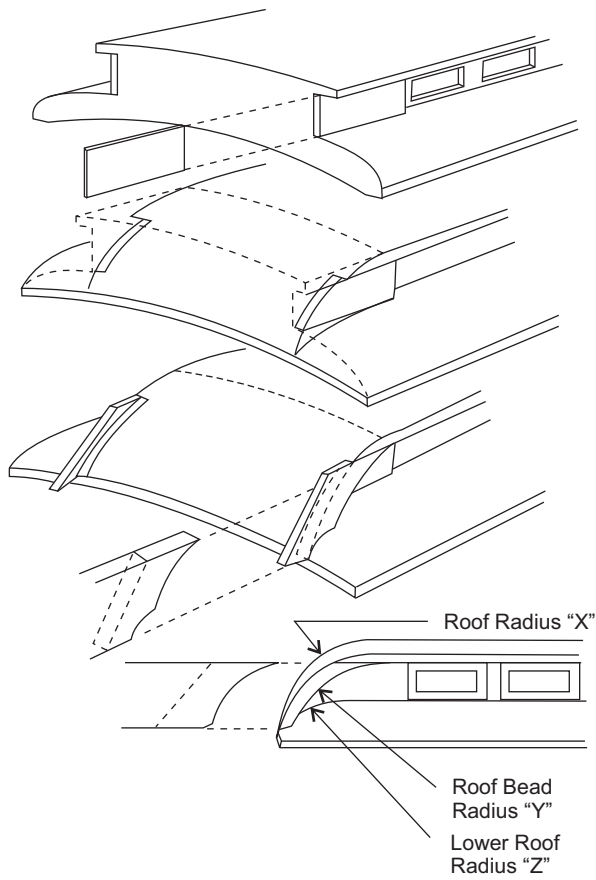

Roof ends may be rounded to contour shown on plan drawing. Make template from card stock and use to check contour for correct shape. Care should be taken when sanding roof ends to size, so as not to sand off too much. This is the point where everybody seems to get nutsy. Curving the roof is not that difficult. First, shape the roof to its rough shape using a knife, Next get a piece of strip sandpaper. While gently holding it against the top of the roof, pull the sandpaper over the rough curved end to smooth out the curve. Always sand with the grain of the wood, never against it. Check frequently with the radius on the instruction sheet or optional roof rounding kit. A few minutes of pulling on the sandpaper and your roof end is done. There, wasn't that simple?

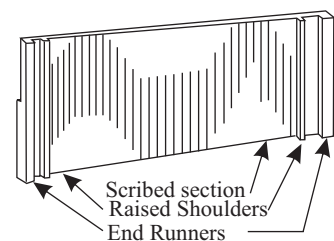
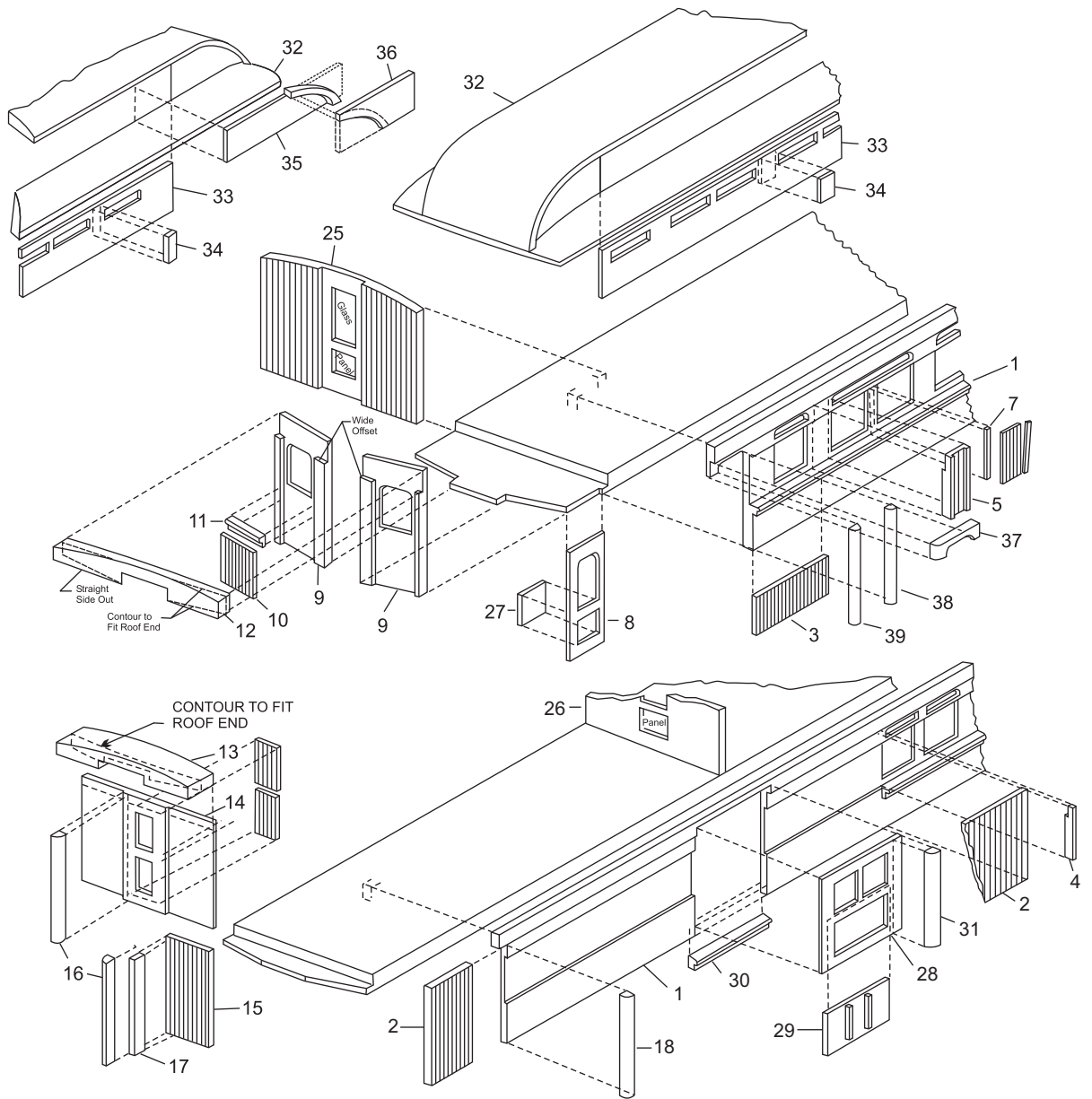

Window Post as Supplied in Kit

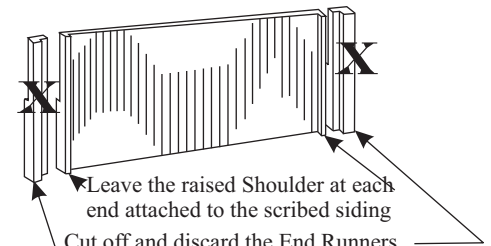

Leave the raised Shoulder at each end attached to the scribed siding
Cut off and discard the End Runners and the thin web attaching them.

LA BELLE WOODWORKING KIT No. HO-1 CLOSED VESTIBULE WOOD COACH

Thank you for buying this LaBelle kit. We are very proud of our kits and believe that they are the best kits of their type in the Model Railroad Hobby. This is basic kit of a 1905 closed vestibule coach. It can be lettered for almost any road and still be correct. It has unlimited possibilities for super detailing. The amount of detailing is up to you. There are many detail parts available from various vendors to customize your car for your railroad.

It is not a “Quickie Kit” and therefore it is suggested that the isometric and plan drawings be studied thoroughly also that parts be sorted and be noted as to where they are intended to be used.

It is suggested that assembly be followed by the numbers in the instructions which correspond with the numbers of the isometric drawing and plan drawing.

These are the sub-sides (1). Separate and cement in place Window Posts (2). Cut paper-thin piece of scribed stock (3), furnished, to fit on small window posts. Separate to form 14 pieces and cement in place.

Cut End Window Posts (5) to approximate width from wide post and cement in place with raised shoulder toward window opening, making sure correct window margin is showing as per plan drawing.

Cement scribed siding (6) below belt rail. Trim flush with ends of sub-side. Cut four doors (8) to size by placing door over template on plan drawing, making sure that two rights and two lefts are made and used on their respective ends. Cut panels from 1/32 by 5/16 inch stripwood and cement to back of doors. Now cement doors to back of sub-side at top Only.

Slightly contour vestibule door headers (7) to match door posts (23) and (24). Cut to fit and cement in place as shown.

Make up four end pieces (9) by cutting scribe siding (10) and also belt rail (11) to fit as shown. Cement (10) on first, then cement (11).

Now cement a completed right and left (9) to end, letter board (12), making sure that wide offset of (9) is to center. Repeat for other end.

Lay out bottom of floor (13) for position of queen posts (21), gas tanks (25), truss rods (27), beams (14), bolsters (15), and brake cylinder (29).

Cement beams (14), bolster (15) and 1/64 by 1/8 inch stripwood beam brace (16) in place, leaving other under body parts off until car body is assembled.

Cement bulkhead walls (17) to floor end as shown, making sure they are square.

Now cement completed sides to floor making sure that end bulkhead walls (17) are slightly below top of sides. Now set car body aside until later.

Start to assemble roof (18) by cementing clerestory window strip (19) inside roof on each side. IMPORTANT: Be sure clerestory windows line up with car side windows. Cut to length (20) and (21) from 1/32 by 3/16 inch stripwood furnished, and cement in place.

Now roof ends may be rounded to contour shown on plan drawing. Make template from card stock and use to check contour for correct shape. Care should be taken when sanding roof ends to size, so as not to sand off too much. This is the point where everybody seems to get nutsy. Curving the roof is not that difficult. First, shape the roof to its rough shape using a knife, Next get a piece of strip sandpaper. While gently holding it against the top of the roof, pull the sandpaper over the rough curved end to smooth out the curve. Always sand with the grain of the wood, never against it. Check frequently with the radius on the instruction sheet or optional roof rounding kit. A few minutes of pulling on the sandpaper and your roof end is done. There, wasn't that simple?

Make up overhang pieces (22) for ends of roof from 1/16 by 1/2 inch stripwood furnished, as shown and cement on. Apply cement to end of floor and bottom of end assembly. Temporarily place roof on car body, holding end assembly up under roof contour and against end of floor until cement has set. You are laminating two pieces to form the end bead,

(21) and (22) allow sufficient time for the glue holding these two pieces to dry.

Remove roof and apply small fillet of cement inside where vestibule ends meet vestibule doors.

After end assembly has set, apply 1/4 round (23) and 1/2 round (24) on vestibule doors as shown.

Make up and apply four gas tanks (25) as shown.

Cement on queen posts (26), install truss rods (27), turn buckles (28), brake cylinder (29) and steps (30).

Make up hand rails (31) and install. Add grab irons (32). Add roof vents (brass escutcheon pins) and chimney.

Car is ready for painting.

After painting, add colored acetate for clerestory windows in roof and upper windows on sides. Don't forget to frost lavatory glass by sanding lightly on backside with fine sandpaper.

Roof may now be cemented in place. Attach diaphragms (not supplied).